

# Chip Trimmer Potentiometer

RH02/RH03 Series

A general purpose, compact, and low-profile type that is suitable for a wide range of applications.

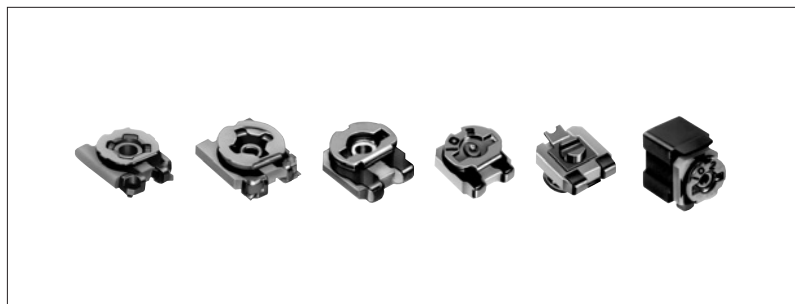

Car Use

Rotary Potentiometers

Slide Potentiometers

Trimmer Potentiometers

Multi Control Devices

Position Sensors

## Features

- A thin, 0.99mm cement trimmer type for automatic adjustments.
- Conforms to JIS C 0806-3 (Packaging of surface mount components on continuous tapes).
- To protect the environment, we use recycled reels, which is compliant with JEITA ET-7200A.

## Applications

- For optical pickup systems in DVD-ROM devices, CD-ROM devices, magneto-optical disks, blue ray disks, DVD players, CD players, MD players and LBP devices to control laser outputs and frequencies
- For LCD modules in LCD monitors, mobile telephones, digital still cameras and mobile communication terminals to control the reference voltage
- For detecting electrical waves and precise adjustment of modulations in ETCs, tuners, codeless telephones, FAX machines, handled wireless radios and STBs
- For adjusting circuits in car navigation systems, car audio systems, home-use audio devices, audio mixers and microwaves
- For adjusting power circuits in PDPs and HDDs
- For adjusting strobe light circuits interlocked with the automatic diaphragm of disposable cameras

Chip-Type

Insertion-Type

## Recommended Products List

Size (mm)	Total resistance (Ω)	Model	Resistance element	Adjusting direction	Soldering	Packing style	Minimum packing unit (pcs.)	Drawing No.
2 (RH02B1C)	220	RH02B1CJ2X	Cermet	Top	Reflow	Brister taping	3,000	1
	470	RH02B1CS2X						
	1k	RH02B1C13X						
	1.5k	RH02B1CE3X						
	2.2k	RH02B1CJ3X						
	3.3k	RH02B1CN3X						
	4.7k	RH02B1CS3X						
	6.8k	RH02B1CW3X						
	10k	RH02B1C14X						
	22k	RH02B1CJ4X						
	47k	RH02B1CS4X						
100k	RH02B1C15X							

## Nonstandard value of resistance

In spite of our recommendation for the total resistance listed above, the following resistance values are also available as nonstandard ones. The area marked by the    shows our recommended resistance value. Other resistance values are treated as non-standard specifications.

Total resistance (Ω)	100	220	470	1k	2.2k	4.7k	10k	22k	47k	100k	220k	470k	1M	2.2M
RH02B1C	12X	J2X	S2X	13X	J3X	S3X	14X	J4X	S4X	15X	J5X	S5X	16X	J6X
Total resistance (Ω)	150	330	680	1.5k	3.3k	6.8k	15k	33k	68k	150k	330k	680k	1.5M	
RH02B1C	E2X	N2X	W2X	E3X	N3X	W3X	E4X	N4X	W4X	E5X	N5X	W5X	E6X	

For other detailed specifications, see P.165

**Recommended Products List**

Size (mm)	Total resistance (Ω)	Model	Resistance element	Adjusting direction	Soldering	Packing style	Minimum packing unit (pcs.)	Drawing No.
3 (RH03ADC)	100	RH03ADC12X	Cermet	Top	Reflow	Brister taping	2,000	2
	220	RH03ADCJ2X						
	330	RH03ADCN2X						
	470	RH03ADCS2X						
	680	RH03ADCW2X						
	1k	RH03ADC13X						
	1.5k	RH03ADCE3X						
	2.2k	RH03ADCJ3X						
	3.3k	RH03ADCN3X						
	4.7k	RH03ADCS3X						
	6.8k	RH03ADCW3X						
	10k	RH03ADC14X						
	22k	RH03ADCJ4X						
	33k	RH03ADCN4X						
	47k	RH03ADCS4X						
	100k	RH03ADC15X						
	220k	RH03ADCJ5X						
470k	RH03ADCS5X							
1M	RH03ADC16X							
2.2k	RH03ADCJ6X							
3 (RH03AXA)	1k	RH03AXA13X	Cermet	Top	Dip/Reflow	Brister taping	2,000	3
	4.7k	RH03AXAS3X						
	10k	RH03AXA14X						
	47k	RH03AXAS4X						
	470k	RH03AXAS5X						
3 (RH03APA)	1k	RH03APA13X	Cermet	Top / Back	Reflow	Brister taping	2,000	4
	2.2k	RH03APAJ3X						
	4.7k	RH03APAS3X						
	10k	RH03APA14X						
	22k	RH03APAJ4X						
	47k	RH03APAS4X						
3 (RH03AVA)	4.7k	RH03AVAS3X	Cermet	Side	Reflow	Brister taping	400	5
	10k	RH03AVA14X						

**Nonstandard value of resistance**

In spite of our recommendation for the total resistance listed above, the following resistance values are also available as nonstandard ones. The area marked by the  shows our recommended resistance value. Other resistance values are treated as non-standard specifications.

Total resistance (Ω)	100	220	470	1k	2.2k	4.7k	10k	22k	47k	100k	220k	470k	1M	2.2M
RH03ADC	12X	J2X	S2X	13X	J3X	S3X	14X	J4X	S4X	15X	J5X	S5X	16X	J6X
RH03AXA	12X	J2X	S2X	13X	J3X	S3X	14X	J4X	S4X	15X	J5X	S5X	16X	J6X
RH03APA	12X	J2X	S2X	13X	J3X	S3X	14X	J4X	S4X	15X	J5X	S5X	16X	J6X
RH03AVA	12X	J2X	S2X	13X	J3X	S3X	14X	J4X	S4X	15X	J5X	S5X	16X	J6X
Total resistance (Ω)	150	330	680	1.5k	3.3k	6.8k	15k	33k	68k	150k	330k	680k	1.5M	
RH03ADC	E2X	N2X	W2X	E3X	N3X	W3X	E4X	N4X	W4X	E5X	N5X	W5X	E6X	
RH03AXA	E2X	N2X	W2X	E3X	N3X	W3X	E4X	N4X	W4X	E5X	N5X	W5X	E6X	
RH03APA	E2X	N2X	W2X	E3X	N3X	W3X	E4X	N4X	W4X	E5X	N5X	W5X	E6X	
RH03AVA	E2X	N2X	W2X	E3X	N3X	W3X	E4X	N4X	W4X	E5X	N5X	W5X	E6X	

**Dimensions**  
2mm Size/3mm Size

Unit : mm

No.	Model	Style	PC board mounting hole dimensions
1	RH02B1C		
2	RH03ADC		
3	RH03AXA		
4	RH03APA		

Rotary Potentiometers  
Slide Potentiometers  
**Trimmer Potentiometers**  
Multi Control Devices  
Position Sensors

**Chip-Type**  
Insertion-Type

## Dimensions

Unit : mm

No.	Model	Style	PC board mounting hole dimensions
5	RH03AVA		<p>Example of pattern</p>

## Terminals layout and circuit diagram

### Chip-type

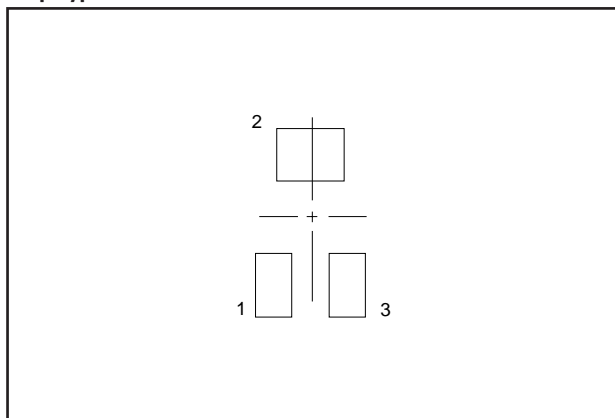

### Circuit Diagram

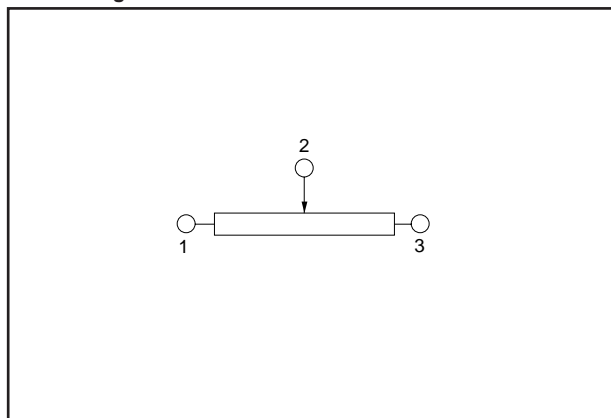

## Recommended adjusting driver

### Adjusting driver of chip trimmer potentiometer

Model	Maker	Product name, Model number		Tip shape	Bit material	Adjustment method
RH02B1C	Toray Industries, Inc.	TORAYCERAM Adjuster	SA-0025	Custom	Ceramic	Manual adjustment
			JB-1303	Regular screw driver		Automatic adjustment
SA-2225			Cross-head screw driver			Manual adjustment
RH03ADC				JB-2225		Automatic adjustment
	—	JIS B 4633	No.1		—	Manual/automatic adjustment
RH03AXA	Toray Industries, Inc.	TORAYCERAM Adjuster	ALS-3001	Regular screw driver	Ceramic	Manual adjustment
RH03APA						
RH03AVA						

## Recommended Cleaning Agents

Please contact us for the recommended cleaning agents for semi-fixed chip volumes.

## Products Specifications

Characteristics	Cermet		
	RH02B1C	RH03ADC	RH03AXA/RH03APA RH03AVA
Operating temperature range	-40°C to +100°C		
Tolerance of nominal total resistance	±25%		
Rated power and maximum operating voltage	0.15W, 50V	0.2W, 50V	
	At 70°C		
Resistance taper	B linear		
Residual resistance	R < 1kΩ:20Ω max. 1KΩ ≤ R:2% max.		
Slider noise	5% max. (JIS C 5261 5.8B)		
Ineffective variable range at both ends	R > 150Ω:10% max. R ≤ 150Ω:20% max.		
Effective rotational angle	250±20°	Total rotational angle 260±20°	250±20°
Rotational torque	0.5 to 15mN·m	1.5 to 15mN·m	2 to 20mN·m
Stopper strength	Endless	20mN·m min.	Endless
Rotational life	20cycles		
Variation in total resistance	±10%		
Long-term heat resistance	100±2°C, 500±12h, 1.5h at nominal temperature and humidity		
Variation in total resistance	±5%		
Moisture resistance	40±2°C, 90 to 95%RH, 500±12h, 1.5h at nominal temperature and humidity		
Variation in total resistance	±5%		
Loading in damp atmosphere	40±2°C, 90 to 95%RH, 500±12h, 5h at nominal temperature and humidity		
Variation in total resistance	±4%		
Operating life with load	70±3°C, 1000±12h, 1h at nominal temperature and humidity		
Variation in total resistance	±5%		
Resistance to soldering heat	Reflow soldering	240°C 10s	
	Dip soldering	—	Only RH03AXA 260°C 5s
Variation in total resistance	±2%		
Temperature coefficient of resistance	-20°C to +100°C		
	±250ppm/°C		±300ppm/°C

Rated power

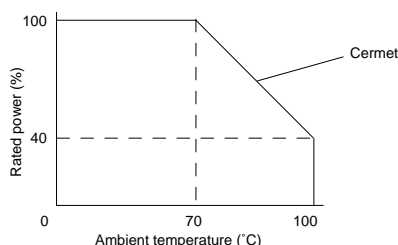

The above curve shall be used when the ambient temperature exceeds 70°C.

# Taping Specifications

## Blister Taping Specifications

Unit : mm

Rotary Potentiometers  
Slide Potentiometers  
Trimmer Potentiometers  
Multi Control Devices  
Position Sensors

Dimension of Blister tape (Conforming to JIS C 0806-3)

Reel dimensions (Conforming to EIAJ ET-7200A)

Applicable models : RH02B1C, RH03ADC, RH03AXA, RH03APA

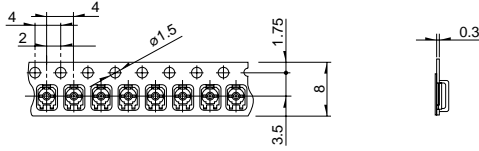

Applicable models : RH03AVA

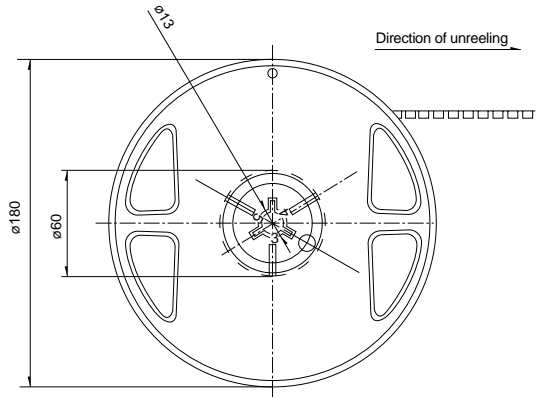
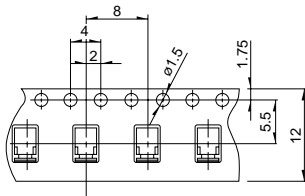

Chip-Type  
Insertion-Type

## Roiling of Tape Package

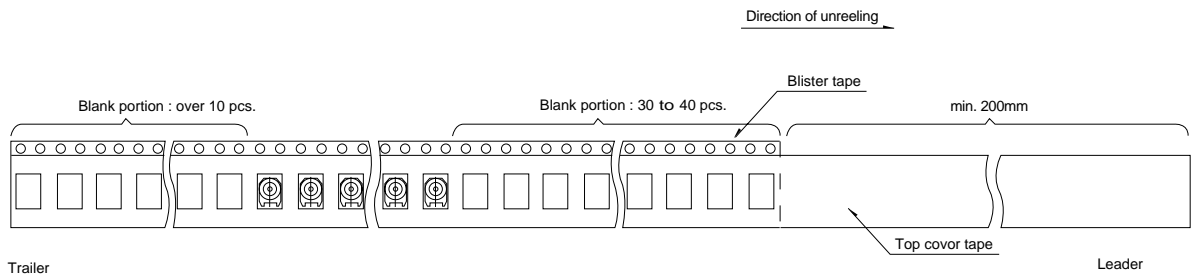

# Soldering Conditions

## [Soldering]

For lead-free models, consult with us individually.

### Insertion Trimmer Potentiometers

Avoid employing wiring designs and soldering methods in which molten solder flows over the upper surface of PC board, as illustrated in the schematic drawing. This can cause occurrences of imperfect contacts.

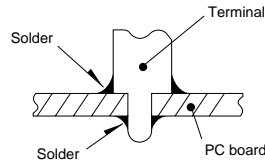

### ① Dip soldering

The products can be flow-soldered under the following conditions.

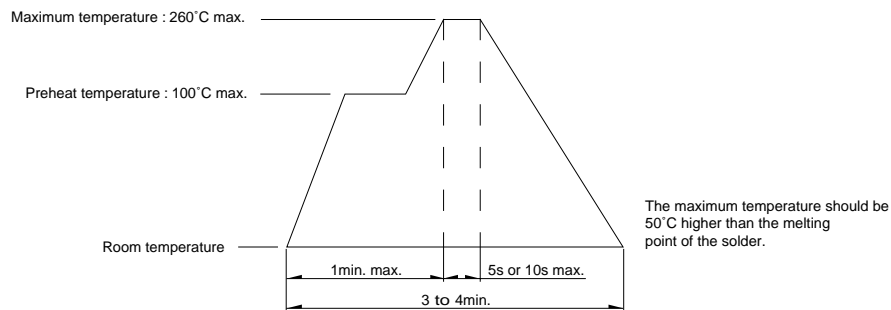

### ② Manual soldering

The products can be soldered manually at a temperature of 350°C max, within 3 seconds.

### Chip Trimmer Potentiometers

#### ① Reflow soldering

The products can be flow-soldered under the following conditions.

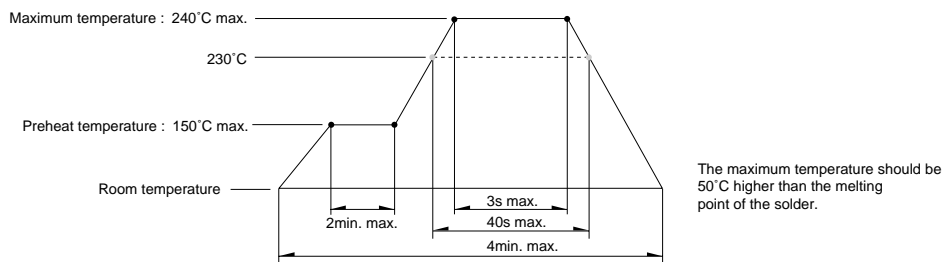

### ② Dip soldering

The products can be flow-soldered under the following conditions.

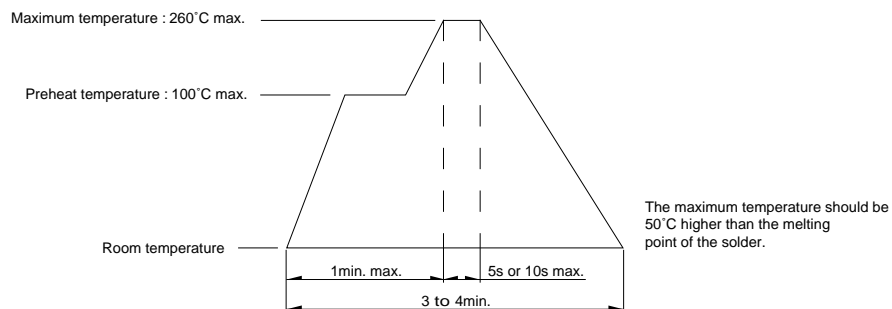

### ③ Manual soldering

The products can be soldered manually at a temperature of 350°C max, within 3 seconds.

Rotary Potentiometers

Slide Potentiometers

Trimmer Potentiometers

Multi Control Devices

Position Sensors

Chip-Type

Insertion-Type